

---

**Contact: Bridgette L. Gollinger**  
DENSO International America  
Phone: (248) 372-8266  
bridgette\_gollinger@denso-diam.com

**For Immediate Release**

Jan. 11, 2010

## **DENSO Develops Battery Monitoring Unit for Lithium-ion Batteries**

*—Using a proprietary voltage control circuit —*

**KARIYA (Japan)** —DENSO Corporation has developed its first battery monitoring unit for lithium-ion batteries used in vehicles. DENSO's new battery monitoring unit utilizes a newly developed voltage control method that uses a simpler and lower cost voltage control circuit, compared to the widely used voltage control method used in laptop computers and other hardware. The new product is installed in the Prius Plug-in Hybrid, which Toyota introduced at the end of 2009.

A battery monitoring unit detects a battery's voltage, current, temperature, and other parameters to enable high-voltage batteries to be used safely and efficiently. Compared to nickel batteries, lithium-ion batteries have a higher energy density, but because lithium-ion batteries consist of multiple cells with fluctuating voltages, it is necessary to control the voltage of each cell.

The conventional voltage control method for lithium-ion batteries converts analog voltage data collected from each cell into a digital form. Then it processes the data by an arithmetic circuit to detect if a cell is operating at a higher voltage and, if so, makes it discharge. DENSO's new voltage control method detects the average voltage of all cells and uses a simple logic circuit to detect if a cell is operating at a higher voltage than the average and making it discharge. The new method performs at the same level as the conventional one, but with a more simple structure that does not need high-performance analog-digital conversion circuits or arithmetic circuits.

Since 1997 when the first Prius hit the market, DENSO has been developing products with battery monitoring technologies. Based on the technologies it has accumulated to date, DENSO will continue to create products for the efficient use of high-voltage batteries.

DENSO Corporation, headquartered in Kariya, Aichi prefecture, Japan, is a leading global supplier of advanced technology, systems and components. Its customers include all the world's major carmakers. Worldwide, the company employs approximately 120,000 people in 33 countries and regions, including Japan. Consolidated global sales for the fiscal year ended March 31, 2009 totaled US\$32.0 billion.

## Battery Monitoring Unit - 2

DENSO common stock is traded on the Tokyo, Osaka and Nagoya stock exchanges. For more information, go to [www.globaldenso.com](http://www.globaldenso.com), or visit our media website at [www.densomediacycenter.com](http://www.densomediacycenter.com). In the Americas, DENSO employs more than 16,000 people, with consolidated sales totaling US\$5.7 billion for the fiscal year ending March 31, 2009. For more information, go to [www.densomedia-na.com](http://www.densomedia-na.com).

### ■ Comparison of voltage control methods

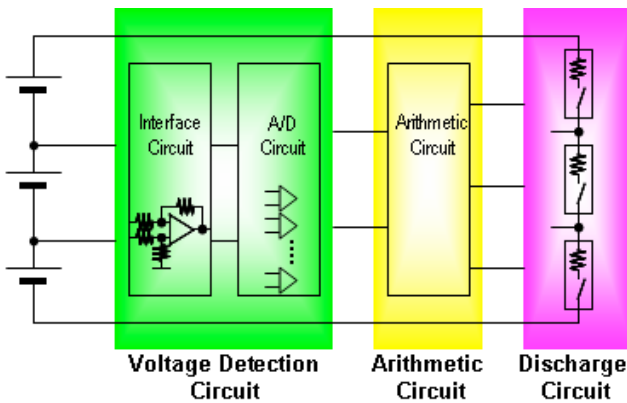

Conventional voltage control method

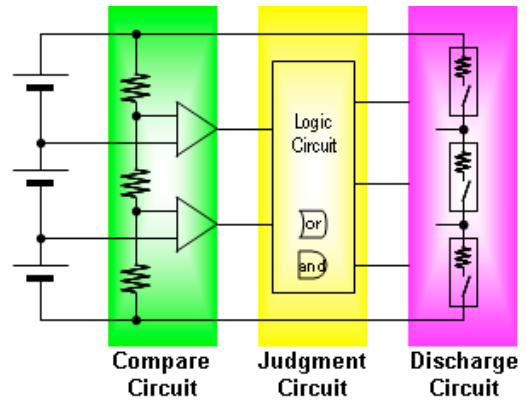

Newly developed voltage control method

###